

Small Propeller Cup: A Proposed Geometry Standard and a New Performance Model

Donald M. MacPherson
VP Technical Director
HydroComp, Inc.

ABSTRACT

A widely used technique to correct and enhance vessel performance is propeller “cup” – a curvature applied to the trailing edge of a propeller blade. Although cupping has become a regular procedure in small propeller shops, it is typically applied without any systematic rules or quantifiable understanding of its effect on performance. The traditional definitions of cup (e.g., light, heavy) vary greatly from one company to the next, and even from one project to the next within the same company. It is the goal of this paper to provide a consistent definition of cup geometry for practical use in industry, as well as a new performance model that can be used in propeller calculations.

INTRODUCTION

Recent evolutionary changes in marine vehicle design and engine performance have resulted in an increasing number of heavily-loaded small propellers. Vessels are continuously pushed faster, and engines of a given size and weight have become more powerful to accommodate this increased demand for performance. Unfortunately, all too often the propeller – the central element in performance – is not considered during early design stages.

Such an oversight results in stern geometries which do not allow for adequate propeller diameter and clearance. The ultimate result is very high thrust loadings leading to noise, vibration and loss of performance due to excess cavitation. Control of cavitation has become the focus of many of the efforts of commercial propeller manufacturers and specialists in the field.

One can always consider a different type of propulsor (e.g., waterjet or surface drive), but if fully submerged propellers are required, there are a few ways to mitigate the problem of excess cavitation:

1. Use cavitation to your advantage (e.g., super cavitating propellers).
2. Prepare a custom design including features such as high skew or camber (also known as progressive pitch).
3. Apply cup to the propeller in conjunction with an appropriate change in pitch.

Custom propellers clearly offer the best hydrodynamic solution to the problem of excess cavitation as they can be designed specifically for the engine, gear and vessel. Custom propellers are not without their shortcomings, however. They are typically effective only within a narrow design range, are costly to manufacture and repair, and require special design capabilities. Also, of course a custom propeller can only replace a poorly performing propeller – one cannot realistically redesign and existing propeller after-the-fact. Propeller cup, while not as hydrodynamically elegant as a proper custom design, can be applied by any competent propeller shop to help resolve poor performance due to excess cavitation. It can also be applied to a new propeller of conventional design.

WHAT IS PROPELLER CUP?

Propeller cup is simply the deformation of a propeller’s trailing edge toward the pressure face (Figure 1). Providing a measure of camber to the blade, it changes the pressure distribution along the blade’s chord length – adding lift toward the trailing edge.

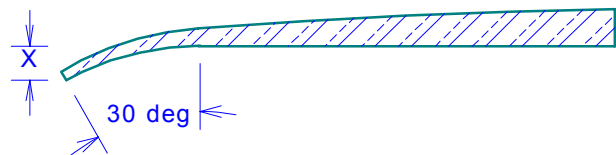

Figure 1 – Example of propeller cup

How is this change in lift distribution useful in controlling cavitation? Typically you will find a peak in the lift distribution somewhere on the leading half of the blade. Cavitation occurs in this region when the local lift is greater than the vapor pressure of the water – causing it to vaporize or “boil”. (This vaporization creates the vapor “cavity” which gives cavitation its name.) Cavitation can be controlled if the peak lift can be reduced below the vapor pressure, while still generating the necessary total lift.

Here is where cup comes in. By adding lift away from the peak via cupping, the entire lift can be reduced by a reduction in pitch. The more we need to reduce pitch to lower the peak lift, the more cup we need to add to compensate for the lost thrust. See Figure 2 below for a descriptive comparison of this effect.

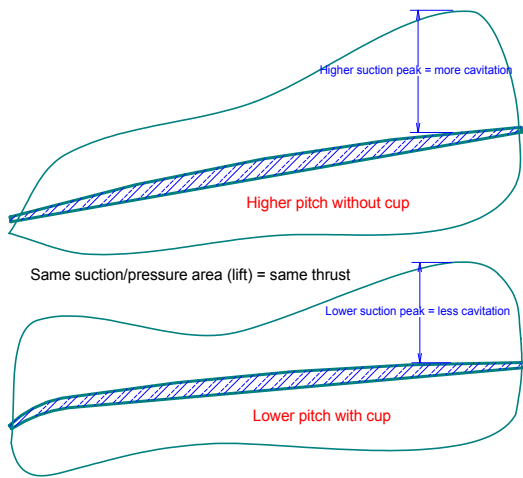

Figure 2 – Performance comparison

The history of propeller cupping is not clear, but has been in use for decades. Unlike progressive pitch propellers, cupping is not generally part of the original propeller design or manufacture. It is indeed an “aftermarket” performance boost applied in the best of propeller shop tradition – *heat it and beat it*. Of course, some shops are more elegant than others about the precision and tolerance of their application of cup.

The lack of consistency in cup geometry is perhaps the greatest individual roadblock to a systematic understanding of the effect of cup on performance. No two organizations use the same definition of cup, and it is common to find differences in the application of cup even within the same shop. We can never develop a methodical understanding of the effects of cup without a consistent definition of the geometry.

A PROPOSED STANDARD DEFINITION OF CUP GEOMETRY

To most members of the general marine community, cup comes in two flavors – *light* and *heavy*. Unfortunately, one person’s light cup is another person’s heavy cup. These trailing edge deformations are very small – typically less than 10 mm (3/8 inch) for the heaviest of cups on most work boat and motor yacht propellers – so differences on such a small scale are easy to appreciate. It is also easy to see why a systematic definition of cup is so important.

Some propeller manufacturers have proprietary systems of rating cup. Cup gauges classed as A, B, C, etc. document the amount of cup which was used and insure that a consistent cup is applied to all blades. Still, a quantifiable system is needed to determine performance changes.

One systematic treatment of the shape and amount of cup was developed by the U.S. Navy’s small craft group (Hankley, 1983) (Denny, 1989). Hankley and Denny used the terms *Light*, *Medium* and *Heavy* to describe the extend of trailing edge drop based on the maximum thickness of the blade. These terms proved to be much more aggressive than commercial terminology. (These terms correlate well to a percentage of diameter for typical commercial propellers. The *Light* cup is typically about 0.5% of diameter, *Medium* is 1% and *Heavy* is 1.5%. Thus, the US Navy *Heavy* cup on a 36 inch propeller suggests more than one-half inch of deflection!) These terms are also subjective and are not “measurable”.

This author proposes a standard definition loosely based on the Hankley/Denny definition described above. The goal is to remove any subjective terms like *Heavy* and *Light*. We propose that cup be defined by:

1. The trailing edge drop in millimeters. (Dimension X in Figure 1.) For example, a propeller might have a 3 mm cup, another a 7 mm cup. No more *Light* and *Heavy*.
2. Cup curvature is to be an arc with a radius 7.5 times the drop, giving an extent of curvature of 30 degrees.

This now gives us a measurable definition with which we will build a performance model to determine how cup does affect thrust and torque.

A NEW PROPELLER CUP PERFORMANCE MODEL

Before considering a new model of cup performance, a review of current views is in order. Starting with the public at large, this author has

witnessed a seriously misguided sense about cup. To quote a few published comments:

- “cupping the prop acts like increased pitch (approximately 1 inch)”
- “select blades with 1 inch or 5 percent less pitch than a similar uncupped blade”
- “they serve no useful function on most vessels operating under 30 knots”
- “add cup and your engine will lose about 200 RPM”

All of the above may be true for individual circumstances, but as universal statements of fact they fall short. These statements assume that all cupping is of the same size and has the same effect on all propellers. Of course, this is not the case. What is useful about the above statements is the notion of “effective” pitch.

In other words, a propeller with cup acts as if it were a propeller with a somewhat higher pitch. (See Figure 2 where the cupped propeller of a lower pitch generates the same thrust as an uncupped propeller of a higher pitch.) The use of effective pitch makes a great deal of sense as it allows us to use conventional propeller performance curves for the analysis of cupped propellers.

Rather than stating that “cup was worth one inch of pitch”, Denny offered a thoughtful analysis of effective pitch. For their *Light*, *Medium* and *Heavy* cups, the authors prepared a chart of effective pitch vs. geometric pitch, and Kt curves for a variety of 3-bladed Gawn-style propellers. Unfortunately, no correlation for torque (Kq) was presented and the authors’ definition of geometric pitch included the cup deformation, making the correlation difficult to evaluate. This has led this author and others in industry to the conclusion that the charts significantly over-estimate the effect of cup. (Full scale analysis of a number of motor yachts by this author also supports this conclusion.) Finally, three magnitudes of cup are inadequate to be useful to the industry at large. A finer distinction is required (i.e., something less than *Light* and between *Light* and *Medium*).

Hwang (Hwang, 1995) reached many of these same conclusions in their presentation of model tests and effective pitch for a 3-bladed Gawn-style propeller. They intentionally used a propeller geometry and *Medium* cup definition following that of Denny. The published results included both Kt and Kq curves over a range of P/D ratios, and show an increase in pitch to be significantly less than that of Denny.

The following simple performance model attempts to eliminate the subjective terms of *Light*, *Medium* and *Heavy*, and follows the more modest pitch increases

from Hwang and HydroComp sea trial data. Based on analysis of model test results and comparisons to full scale trial results, it was found that the value of the geometric pitch had little effect on the increase in pitch. Only the amount of cup deformation influenced the effective pitch.

The new performance model is:

$$P_{EFF} = P_{GEO} + 21(X_{CUP})$$

where, P_{EFF} = effective pitch
 P_{GEO} = geometric (uncupped) face pitch
 X_{CUP} = trailing edge deformation (drop)

For example, the 250 mm propeller from Hwang had an average cup of 1.85 mm. The effective increase in pitch would then be approximately 39 mm. A summary of geometric pitch, calculated effective pitch (from the above relationship) and as-tested equivalent pitch (from corresponding Kt/Kq curves) is shown below.

P_{GEO}/D	P_{GEO}	P_{EFF}	P_{EQUIV}
0.8	200	239	240 (0.96 P/D)
1.0	250	289	285 (1.14 P/D)
1.2	300	339	340 (1.36 P/D)
1.4	350	389	390 (1.56 P/D)

Table 1 – Corresponding effective pitch

At no point was the calculated effective pitch more than 2% from the tested equivalent pitch, and there was very good correlation with both Kt and Kq. So, to find the necessary cup, first determine the pitch increase needed for performance and then divide the pitch increase by 21.

There is one final point to remember when using this performance model. As you can see, effective pitch can increase substantially with cup. One must be sure to check that the effective pitch does not exceed the range of P/D ratio in the data set of the Kt/Kq formula. For example, the above propeller with a geometric pitch of 400 (1.6 P/D) is within the upper limit of the Gawn-AEW equations (Blount, 1981), but the effective pitch of 439 mm (1.76 P/D) is outside of the range and the extrapolated results may be unreliable.

Cavitation and effective pitch

How is cavitation evaluated for a cupped propeller? The simple answer is that while performance corresponds to a propeller with a higher effective pitch, the levels of cavitation correspond to the geometric pitch of the propeller ahead of the cup.

The traditional criteria for cavitation are all empirically-derived functions of blade pressure (MacPherson, 1991). They were developed over time to represent relationships between amounts of cavitation and “average” blade pressure for conventional (uncupped) propellers. To use these criteria with cupped propellers, it is necessary to calculate two different thrust values – a performance thrust at the effective pitch and then a theoretical “cavitation thrust” calculated at the geometric pitch. Average blade pressure, subsequent levels of cavitation and thrust loss are then derived from this “cavitation thrust”.

MEASUREMENT OF CUP

Knowing how much cup to apply is only half of the battle. The other half is actually getting the proper cup onto the propeller. Using the geometric definition of cup corresponding to Hankley and Denny, this author suggests the use of a propeller cup gauge similar to that shown in Figure 3.

Each gauge is labeled for the amount of trailing edge deformation (drop) in millimeters (e.g., 5 mm). It would have a step of the proper dimension (e.g., 5 mm) to measure the drop, and a radius of 7.5 times the drop (e.g., 37.5 mm) to measure the curvature. Two marks of 0 and 30 degrees would be scored on the radius to show the extent of curvature. A typical propeller shop would have gauges in 1 mm increments up to 10 mm or so.

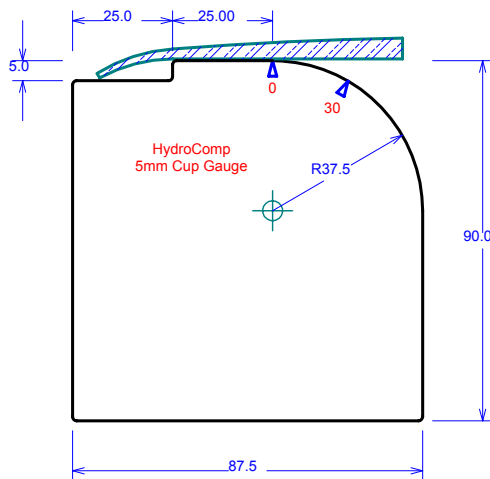

Figure 3 – Cup gauge

Consistency of pitch and cup is very important, so industry practice is to apply the same amount of cup across the blade. Typically, the required cup would be fit from the mid-radius (40%-50%R) to near the tip

(90%R), with a smooth transition to no cup at both extents. (One note of interest: a few companies have had some success in varying the cup distribution, typically with greater cup near the tip, in an attempt to fine-tune performance at various speeds.)

CONCLUSION

The simple geometric definition and performance model described above are intended to bring some sense of consistency to the community of propeller manufacturers, after-market propeller shops, naval architects and other marine professionals interested in cupped propeller performance. An earlier generation of the performance model implemented in a commercial software package (HydroComp, 1996) has been used successfully by dozens of marine professionals for numerous new and repowered vessels.

Work is continuing to improve the performance model by segregating thrust and torque, by evaluating the effect of other propeller parameters (e.g., mean width ratio) and by refining the relationship with new data from model tests and sea trials, particularly for 4- and 5-bladed propellers of very high blade area.

REFERENCES

Blount, D.L. and Hubble, E.N., “Sizing Segmental Section Commercially Available Propellers for Small Craft”, SNAME Propeller Symposium, 1981.

Denny, S.B., Puckette, L.T., Hubble, E.N., Smith, S.K. and Najarian, R.F., “A New Usable Propeller Series”, *Marine Technology*, Vol. 26, No. 3, July 1989.

Hwang JL, Tsai JF and Li CY, “Cupped Propeller Test and Analysis”, *Ship Technology Research*, Vol. 32, 1995.

Hankley, D.W. and Denny, S.B., “Performance Characteristics for a Series of Commercially Available Propellers for Small Craft”, SNAME, San Diego Section, Feb 1983.

HydroComp, Inc., *HydroComp PropExpert™* program and documentation, 1996.

MacPherson, D.M., “Reliable Propeller Selection for Work Boats and Pleasure Craft: Techniques Using a Personal Computer”, SNAME Power Boat Symposium, 1991.

DISCUSSION

Dudley Dawson, P.E., Member

I'd like to thank the author for this significant contribution to the field of small craft propeller technology. As a designer specializing in power vessels up to about 60 meters in length, I am well aware of the current uncertainties and problems in specifying propellers with an unquantified light, medium or heavy cup. The proposed measurement system will address these problems, but only if propeller manufacturers and distributors put into place a system of implementing and verifying cup dimensions. It is up to naval architects and marine engineers to use the system regularly in their specifications and insist that suppliers adhere to it. Once it has been given a fair trial and any bugs worked out of the system, then an ABYC or SAE standard formalizing the measurement system would be in order.

In addition to those cited in the paper, there are several other reasons that the specification of cup may be desirable. One of the unfortunate trends in modern power vessel design and construction is a general increase in both weight and power for a vessel of given physical dimensions. While weight and power have increased, indicating additional propeller blade area, the depth of water has not increased in the Caribbean for yachts nor in the Gulf of Mexico for crewboats nor in rivers for workboats and ferries. Some commercial vessels have addressed this problem by installing additional propellers (4 or more) of the same limited diameter. Although there are a few yachts with 3 engines and propellers, most have been limited to 2 engines and propellers by owner demands. For this market, the use of hull-bottom propeller tunnels with larger diameter, high-area ratio propellers is finding increased acceptance (Dawson, 1997). In many cases, this is sufficient to provide the necessary propeller blade area without increased draft but in some extreme cases, the specification of cup in a new installation is necessary to avoid or abate cavitation that cannot be designed out by other means.

There are also sound economic reasons for specifying cup in a new installation. It is generally much less expensive to include cup in a manufacturer's stock propeller than to specify a custom propeller with cambered and skewed blade patterns. Often, the theoretical difference in performance is quite small, and in full-scale tests, unmeasurable. Also, one of the most common uncertainties between the preliminary design and complete vessel stages is the full-load displacement of the vessel as built, and it is for this condition that most propellers should be specified. By specifying a

propeller that is slightly underpitched, but provided with moderate cup, the problems of under- or over-displacement (cavitation, inability to attain full engine RPM, inability to attain full power loading or speed) can often be addressed by adjustments in cup rather than having to repitch the propellers.

Although both the title and the text of the paper indicate that the proposed measurement system and effective pitch methodology are for small craft and small propellers, no quantification of "small" is given. It would be of benefit if the author could indicate recommended lower and upper limits based on the trial data used and his verification of the methodology.

Finally, there is one item of practical concern. The author proposes that the radius of the cup vary directly as a percentage of the drop (or deflection), resulting in a discrete radius for each value of drop, and larger radii for larger drops (heavier cups). Many of the propeller shops working on small propellers are indeed of the "heat it and beat it" variety with a minimal investment in equipment. Often, current practice is for a piece of round steel bar stock to be used as a rough mandrel to cup the trailing edge, and light vs. heavy cup is thus a matter of varying the extent rather than the radius of the curved portion. Also, when an existing heavy cup is modified to a light cup, it is often done by bending the trailing edge back toward the flat, so a lighter cup may end up with more radius than a heavy one. The author's comments on technical considerations of the two differing systems would be appreciated, along with his thoughts on whether it would be possible to use a discrete number of mandrel radii (say, 2 or 3) to cover the range from 1 to 10 millimeters of cup without significant loss of effectiveness.

Additional reference

Dawson, D.A., "Faster, Farther, and More Fuel-Efficient", *Professional BoatBuilder*, No. 44, December/January 1997.

Author's Closure

Many thanks to Mr. Dawson for his real-world perspective on the use of cupped propellers. They are a valuable addition to the paper.

Regarding acceptance of the measurement system by some regulating body (e.g., ABYC, SAE), any system will have to stand on its own merits – and this proposed system is no exception. It is my hope that this

will not be the industry's final effort on this topic, but will lead to additional interest, research and practical development.

The term "small" is meant nothing more than to provide some scope for the topic. As the fundamental research was conducted and trial data evaluated on propellers germane to small vessels (i.e., diameters under about 32"), the model should not be extrapolated to large propellers. Fortunately since cupping is typically a "small" propeller practice, extrapolation to larger diameters is moot.

Using a smaller mandrel to extend the cup onto the blade so as to create an "effective" radius of cup would depend on the skill of the craftsman, I suppose. Unfortunately, I have no data to support or dismiss this from a performance standpoint. I would not endorse altering the proposed geometry, however, simply because it is the way that things are done today. Cupping is indeed a "performance tweak", and it is not unreasonable to suggest that if propeller builders and vendors want to develop this expertise, then they should have the proper tools – just as they do now with a range of proper pitch blocks or even digital measurement devices, for example.

My thanks again to Dudley Dawson for his comments and to Peter Lapp of the Bird-Johnson Company for this technical review.